

**DRS
RP
Dri-Fit™**

**Rails
Headers
Glazing Systems**



Innovation and quality made easy. DORMA DRS Rail System with Easi-Align™ and Dri-Fit™.

The DRS Rail System—the original clamp-on rail system from DORMA—allows for the easiest and quickest door assembly of any rail system on the market.

DRS Rails are delivered with all DORMA hardware installed and prepped. Simply clamp the rails onto a piece of tempered glass and the system is ready for installation. The DRS clamp-on system allows for job-site door height adjustment to compensate for irregularities in the door opening.

Additionally, the snap-on rail covers need not be installed until job inspection, keeping construction site damage to a minimum.

DORMA DRS Rails feature Easi-Align™ adjustable prep blocks for setting door clearances and pivot centers while the door is installed. With Easi-Align, one rail size—35-3/4" (908 mm)—can be used for openings of 36" (914 mm) or 72" (1829 mm). This feature reduces stocking requirements, shortens lead times, and simplifies ordering requirements.

Innovative design, quality materials, and the finest workmanship mean that the DRS Rail System has features to meet the most demanding conditions. The system has been independent-laboratory tested for holding force under

any climate condition. Tested at temperatures ranging from -10° to 150°, the DORMA DRS rail pull tested for over 3000 lb (1364 kg) per 3' (914 mm) under the worst conditions, and for over 5000 lb (2273 kg) in the best conditions, all without failure or slippage.

Dri-Fit™ sidelite rails are offered to match door profiles, plus a complete range of saddles to match clearances.

For easy glazing that eliminates the need to use silicone during glass installation, top and bottom Dri-Fit U-channels are also available.

DRS system heights are:

- 3-5/8" (92 mm)
—square or tapered
- 4" (102 mm)—square
- 6" (152 mm)—square
- 10" (254 mm)—square

All heights accommodate 3/8" (10 mm) and 1/2" (12 mm) width glass.

3-5/8" (92 mm) and 6" (152 mm) systems (square only) can also accommodate 5/8" (15 mm) and 3/4" (19 mm) thick glass.

The DRS Rail System offers nine stock finishes (page 4). Custom finishes are also available.

DORMA DRS at a glance

- On-site height adjustability
- Snap-on covers
- On-site glass replacement
- Mechanical clamp-on system featuring the Hakosil gasket as utilized in DORMA Patch Fittings
- Doors can be prepared for a full range of DORMA architectural hardware
- Can be used in conjunction with the DORMA header system
- One-stop shopping for rails, sidelites, fittings, headers, and handles
- DORMA's worldwide reputation as an industry leader

Technical Data

Glass thickness

3/8" (10 mm)
1/2" (12 mm)
5/8" (15 mm)
3/4" (19 mm)
(see table next page)

Max width

48" (1219 mm) w/
BTS floor closer
42" (1067 mm) w/ RTS
overhead closer
(GANA guidelines)

Warranty 1 year





DRS Mechanical Rail Section Details

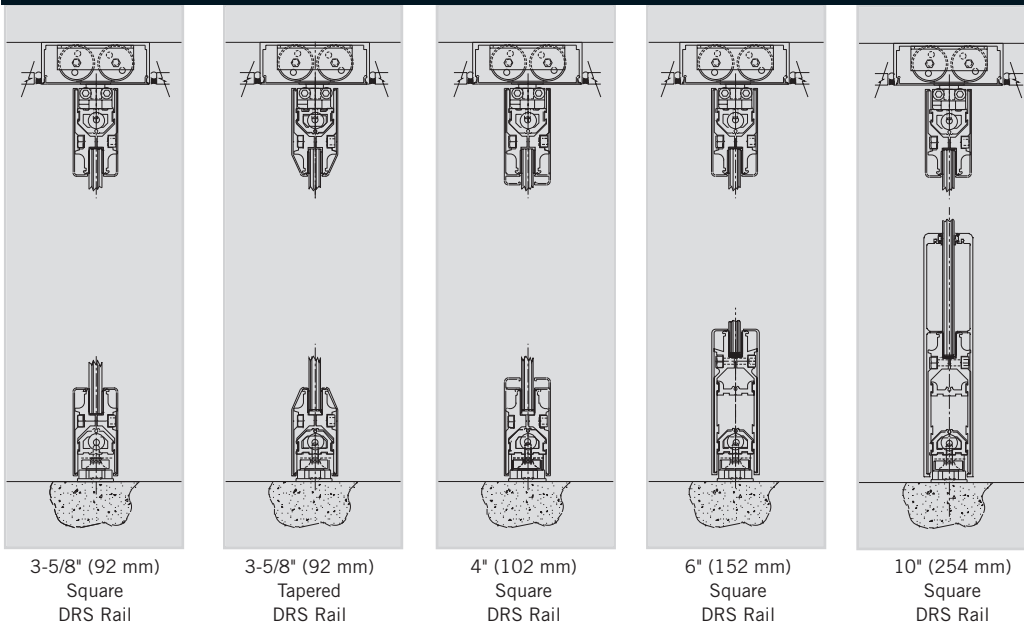

Glass Thickness Availability					
Glass Thickness (fully tempered)	3-5/8" (92 mm) SQ DRS Rail	3-5/8" (92 mm) TP DRS Rail	4" (102 mm) SQ DRS Rail	6" (152 mm) SQ DRS Rail	10" (254 mm) SQ DRS Rail
3/8" (10 mm) or 1/2" (12 mm)	X	X	X	X	X
5/8" (15 mm) or 3/4" (19 mm)	X			X	

The DRS/RP/Dri-Fit system comes in nine stock finishes or custom finishes upon request.



Clear Anodized (101)



Dark Bronze Anodized (108)



Black Anodized (109)



Polished Stainless Steel (701)



Polished Brass (503)



Polished Bronze (601)



Satin Stainless (700)



Satin Brass (599)



Satin Bronze (600)

Invisible door control, dependable and ready to install. DORMA RP Headers.

Design professionals are often challenged to design buildings that are both beautiful and functional down to the last detail. DORMA RP header tubes are made to house the RTS overhead concealed closers and a variety of other pivot options.

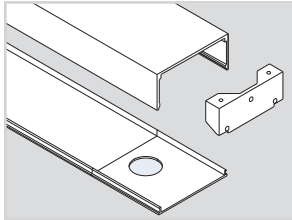

The popularity of concealed overhead closers has led DORMA to furnish fully fabricated headers for every door and sidelite configuration. Headers are available in two profiles:

- 1-3/4" × 4-1/8" (44 mm × 105 mm)
- 1-3/4" × 4-1/2" (44 mm × 114 mm)

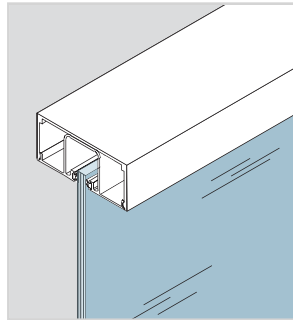

The design of the DORMA RP header system allows for a glazing pocket to be snapped into the header tube to permit a seamless transition to the sidelite glazing. The Dri-Fit gasket is used for quick and easy installation. Profiles are available for glass thicknesses of 3/8" (10 mm), 1/2" (12 mm), 5/8" (15 mm), and 3/4" (19 mm) tempered glass.

RP Header tubes are available in all nine standard finishes.

RP Header Section Details

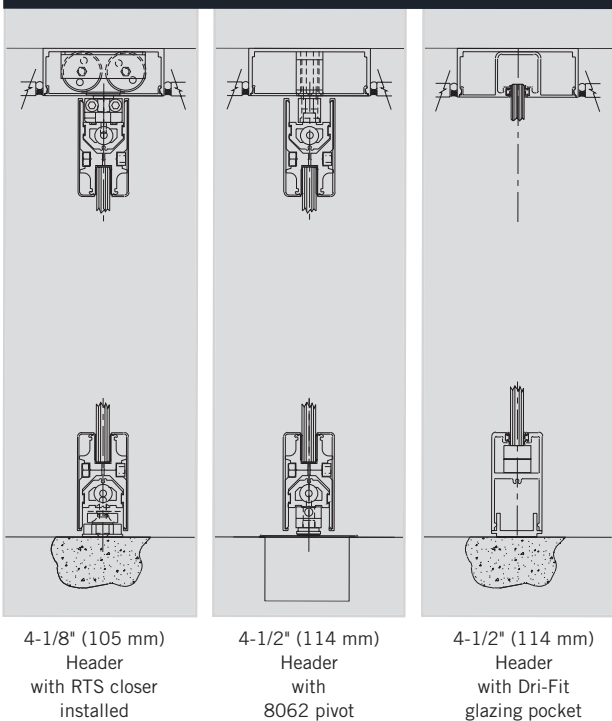



Simplified glazing, minimal hardware. DORMA Dri-Fit.

The DORMA Dri-Fit system simplifies glazing installation. The intelligently designed Dri-Fit gasket is used in sidelite rails, header tube glazing pockets, and u-channels.

Dri-Fit side rails are available to match all DRS mechanical profile heights and offer a number of saddle sizes from 1/8" to 3/4" (3 mm to 19 mm) tall.

The Dri-Fit glazing system accommodates glass thicknesses of 3/8" (10 mm), 1/2" (12 mm), 5/8" (15 mm), and 3/4" (19 mm). See the table on page 7 for more details.

In addition to Dri-Fit sidelite rails, DORMA also offers the Dri-Fit U-Channel—a low profile u-channel ideal for glazing with minimal hardware. It can even be recessed in the ceiling and floor to completely eliminate visible hardware.

Both Dri-Fit sidelite rails and Dri-Fit U-Channels are available in all nine stock finishes (page 4). Extrusions are available in stock lengths up to 144" (3658 mm) [120" (3048 mm) for Brass and Bronze finishes].

The DORMA Dri-Fit system simplifies glazing installation.

Dri-Fit Sidelite Rail Profiles

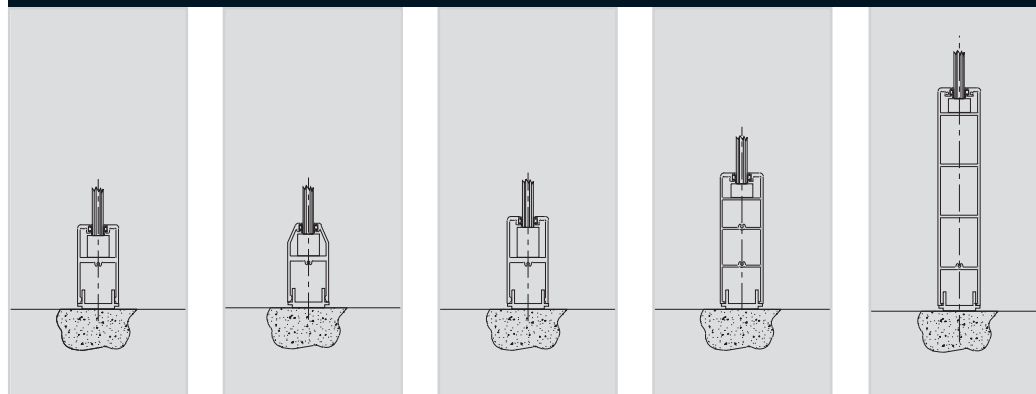

3-5/8" (92 mm)
Square
Dri-Fit Rail

3-5/8" (92 mm)
Tapered
Dri-Fit Rail

4" (102 mm)
Square
Dri-Fit Rail

6" (152 mm)
Square
Dri-Fit Rail

10" (254 mm)
Square
Dri-Fit Rail

Dri-Fit U-Channel Profiles

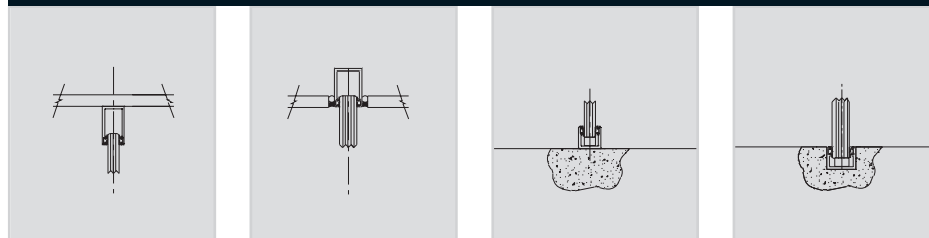

1" x 1-3/4"
(25 mm x 44 mm)
Top Dri-Fit
U-Channel
(shown flush mounted)

1-1/4" x 1-3/4"
(32 mm x 44 mm)
Top Dri-Fit
U-Channel
(shown recessed)

1" x 1"
(25 mm x 25 mm)
Bottom Dri-Fit
U-Channel
(shown flush mounted)

1-1/4" x 1"
(32 mm x 25 mm)
Bottom Dri-Fit
U-Channel
(shown recessed)

Glass Thickness Availability

Glass Thickness (fully tempered)	3-5/8" (92 mm) SQ Dri-Fit Rail	3-5/8" (92 mm) TP Dri-Fit Rail	4" (102 mm) SQ Dri-Fit Rail	6" (152 mm) SQ Dri-Fit Rail	10" (254 mm) SQ Dri-Fit Rail	1" x 1" (25 mm x 25 mm) Dri-Fit U-Channel	1" x 1-3/4" (25 mm x 44 mm) Dri-Fit U-Channel	1-1/4" x 1" (32 mm x 25 mm) Dri-Fit U-Channel	1-1/4" x 1-3/4" (32 mm x 44 mm) Dri-Fit U-Channel
3/8" (10 mm) or 1/2" (12 mm)	X	X	X	X	X	X	X		
5/8" (15 mm) or 3/4" (19 mm)	X			X				X	X



DORMA USA, Inc.
Dorma Drive, Drawer AC
Reamstown, PA 17567
800-523-8483
www.dorma.com